

■ Proportional Electro-Hydraulic Pressure Control Valves

These are Closed-Loop type pressure control valves controlling the system pressure from low to high in proportion to the input voltage. The stable pressure control is possible even in a small flow rate.

■ Specification

Model Number		SB1110	SB1190
Description			
Max. Operating Pres.	Kgf/cm ²	B: 70 H: 250	B: 70
Max. Flow	L/min.	30	70
Min. Flow	L/min.	B: 0.5 H: 0.5 (at 2 ~ 70 Kgf/cm ²) 1.5 (at 70 ~ 160 Kgf/cm ²) 3.0 (at 1600 ~ 250 Kgf/cm ²)	1
Pres. Adj. Range		Refer to Model No. Designation	
Coil Resistance	Ω	10	
Hysteresis		1% or Less	1.5% or Less
Repeatability		1% or Less ^{*1}	
Supply Electric Power		24V DC (21 to 28V DC included Ripple)	
Power Input (Max.)	W	28	
Input Signal Voltage (at Max. Flow)		B: 70 Kgf/cm ² / 5V DC H: 250 Kgf/cm ² / 5V DC	70 Kgf/cm ² / 5V DC
Input Impedance	kΩ	10	
Alarm Signal Output (Open Collector)		Voltage: Max. 30V DC Current: Max. 40 mA	
Pressure Signal Output		B: 5V DC / 70 Kgf/cm ² C: 5V DC / 160 Kgf/cm ² H: 5V DC / 250 Kgf/cm ²	5V DC / 70 Kgf/cm ²
Ambient Temperature		0 - 50°C (With Circulated Air)	
Mass	Kg.	3.3	10.2

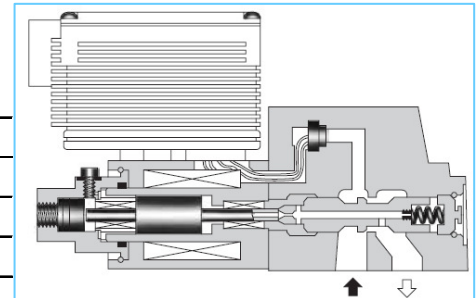
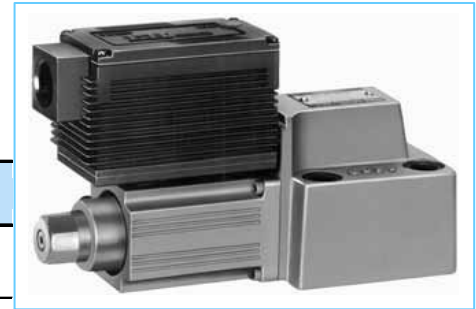

Graphic Symbol

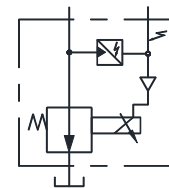

^{*1}The repeatability of the valve is obtained by having it tested independently on the conditions similar to its original testing.

■ Model Number Designation

F-	SB1110	-B	-20
Special Seals	Series Number	Pressure Adj. Range Kgf/cm ²	Design Number
F: Special Seals for Phosphate Ester Type Fluid (Omit if not required)	SB1110: Proportional Electro-Hydraulic Pressure Control Valve (3/8, Sub-plate mounting)	B: 2 ^{*1} ~ 70 H: 2 ^{*1} ~ 250	20
	SB1190: Proportional Electro-Hydraulic Pressure Control Valve (3/4, Sub-plate mounting)	B: 2 ^{*1} ~ 70	10

^{*1}The minimum adjustable pressure is the value obtained at maximum flow.

■ Mounting Bolts

Model Number	Socket head cap Screw	Qty	Bolt Kit Number
SB1110	M12 x 65Lg.	4	BKSB1110-20
SB1190	M16 x 100Lg.		BKSB1190-10

■ Sub-Plate

Sl. No.	Model Numbers	Sub-Plate Model Numbers	Thread size	Mass Kg.
1	SB1110	BGM-03-3080	3/8 BSP.F	2.4
		BGM-03X-3080	1/2 BSP.F	3.1
2	SB1190	BGM-06-3080	3/4 BSP.F	4.7
		BGM-06X-3080	1 BSP.F	5.7

- Sub-plates are available. Specify sub-plate model number from the table above. When sub-plates are not used, the mounting surface should have a good machined finish.
- For Sub-plates details please refer page no. 272.

■ Instructions

- **Safety Valve**
As the function of safety valve has not been included in the valve itself, provide safety valve in the hydraulic circuit if required.
- **Piping to the Reservoir**
The tank port should be connected directly to the reservoir. Be sure the end of pipe is dipped in to the oil in the reservoir.
- **Low Flow Rate**
The preselected pressure may become instable. To avoid such pressure instability, the flow rate should not be lower than minimum flow.

● **SB1110-※-20**

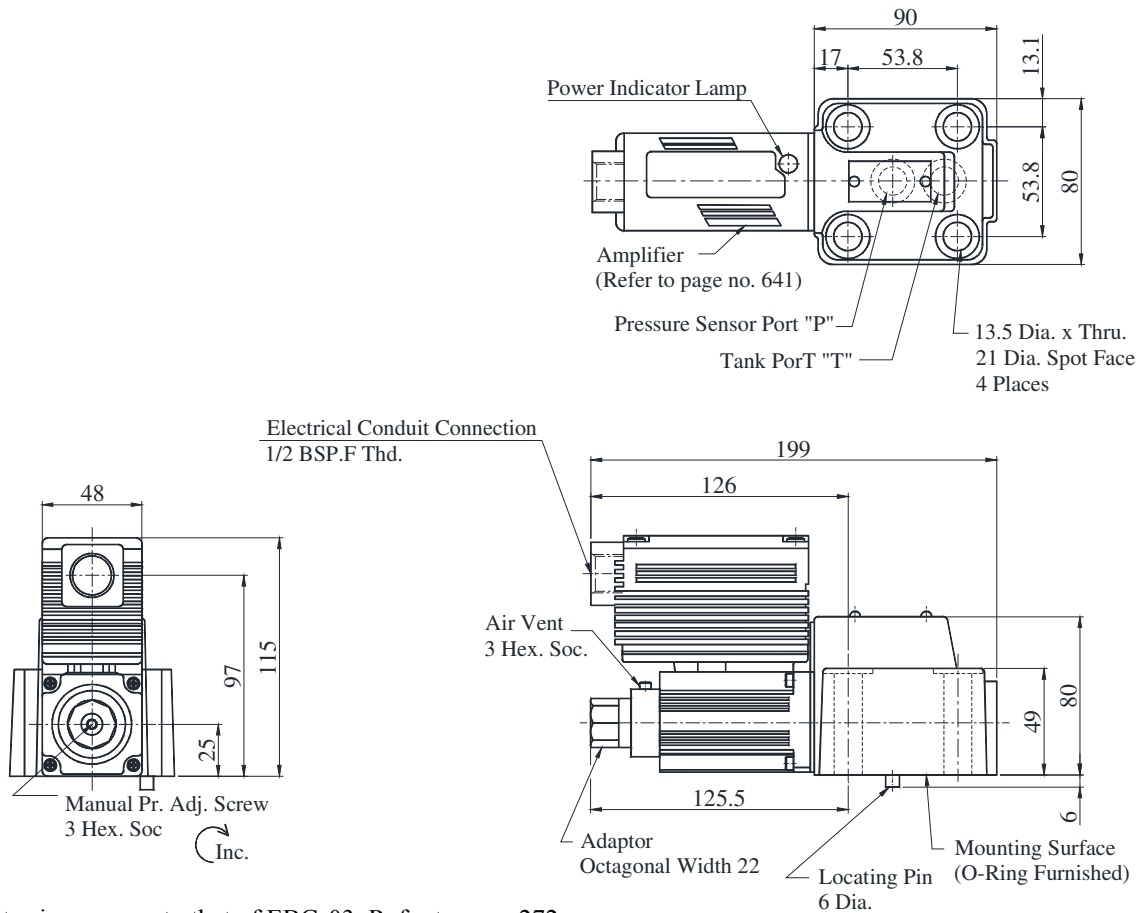

● Sub-plates is common to that of EBG-03. Refer to page 272 for the dimensions of mounting surface.

DIMENSIONS IN MILLIMETRES

● **SB1190-B-10**

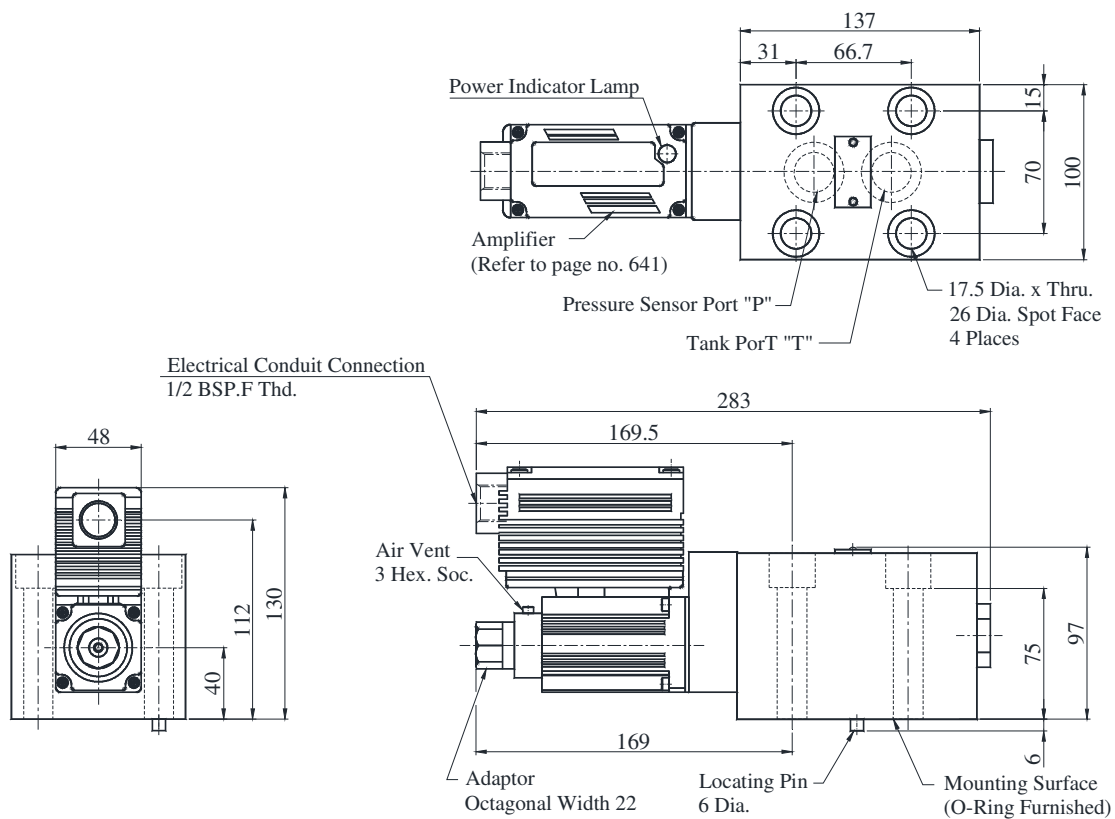

EH Series

Proportional Electro-Hydraulic Pressure Control Valves

Min. Adjustment Pressure

● SB1110

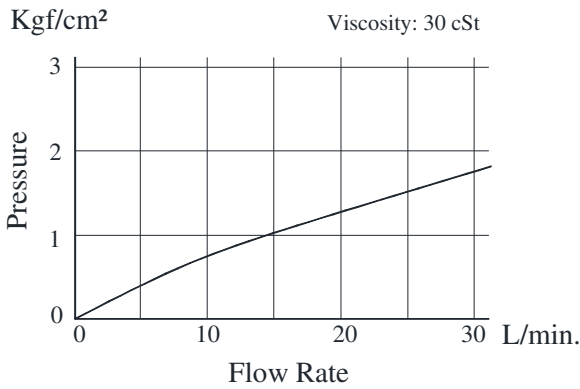

● SB1190

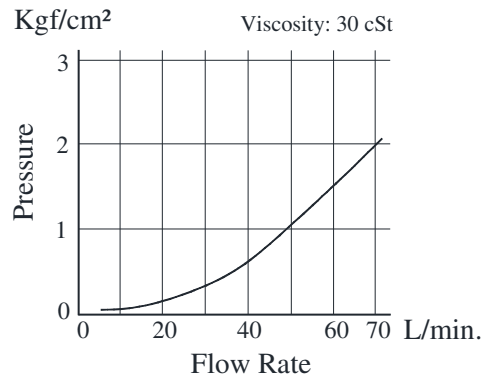

Input Signal Voltage Vs. Pressure

● SB1110

Flow Rate : 30 L/min.
Viscosity : 30 cSt

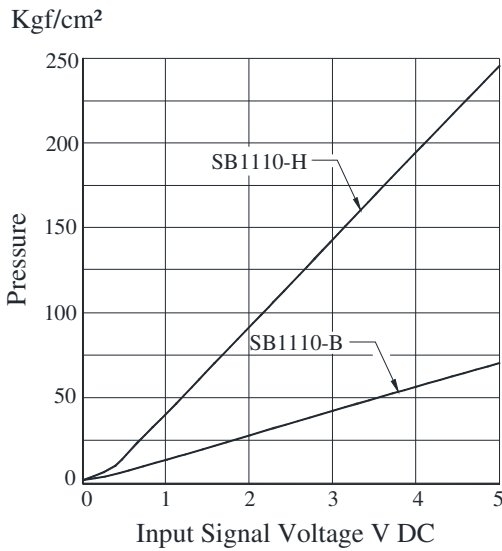

● SB1190

Flow Rate : 70 L/min.
Viscosity : 30 cSt

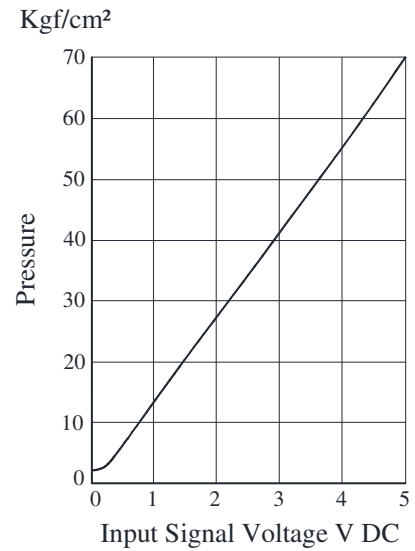

Flow Rate Vs. Pressure

Flow Rate : 30 L/min.
Viscosity : 30 cSt

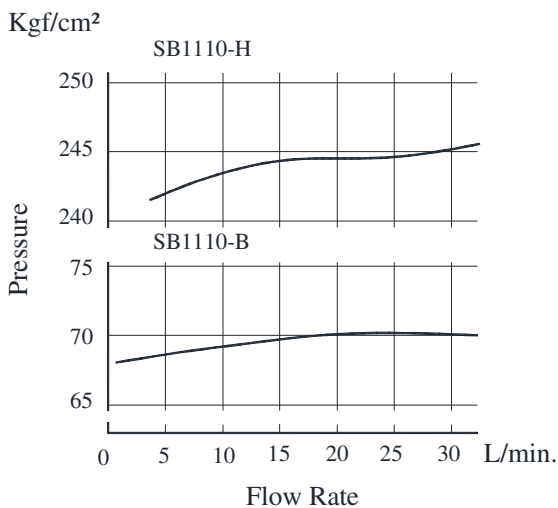

● SB1190

Viscosity : 30 cSt

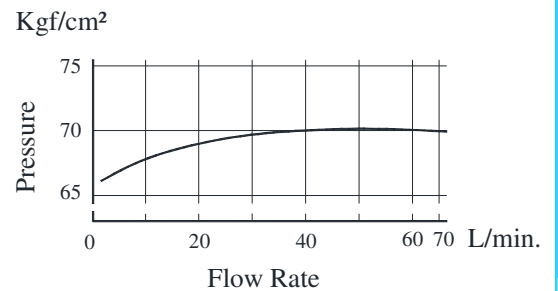

Viscosity Vs. Pressure

Flow Rate : 30 L/min.
Oil : ISO VG 46

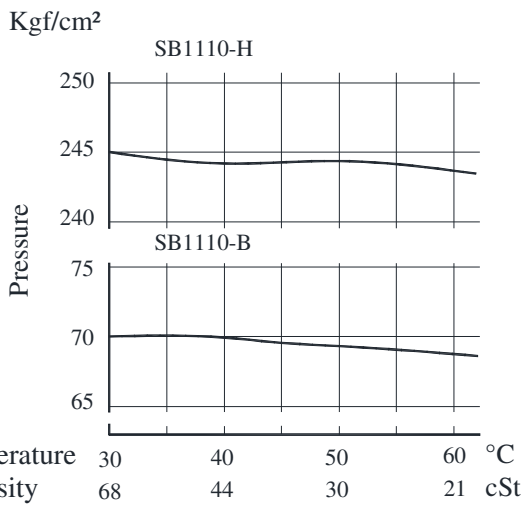

SB1190

Flow Rate : 70 L/min.
Oil : ISO VG 46

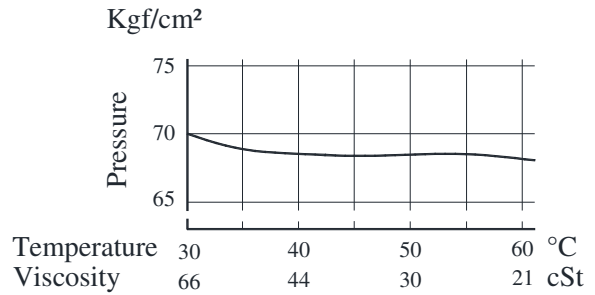

Frequency Response

Flow Rate : 30 L/min.
Pressure : 80 ±16 Kgf/cm²
Trapped Oil Volume : 500 cm³
Viscosity : 30 cSt

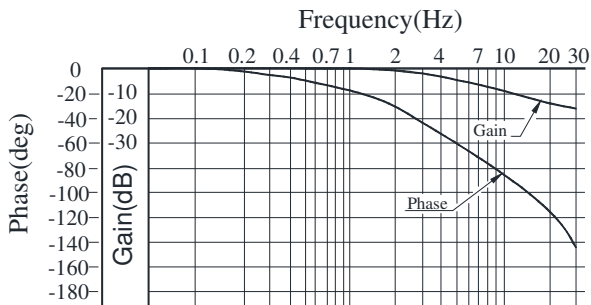

Flow Rate : 70 L/min.
Pressure : 35 ±7 Kgf/cm²
Trapped Oil Volume : 1035 cm³
Viscosity : 30 cSt

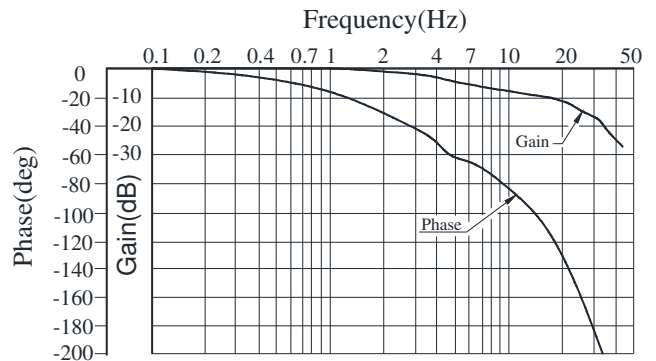

Step Response (Example)

The step responses below are those obtained when the valve itself is tested independently. The step responses may differ from them when the valve is used in combination with other control valves.

Flow Rate : 30 L/min.
Trapped Oil Volume : 500 cm³
Viscosity : 30 cSt

Flow Rate : 70 L/min.
Trapped Oil Volume : 1035 cm³
Viscosity : 30 cSt

